



OVIVO
Bringing water to life

Seawater to pure Water

Boiler Feed water from Seawater at the
Isle of Grain Power Station

Chris Bell 28/10/2010

Introduction

1. OVIVO.

2. Back ground on the Grain project.

3. Installed Equipment.

OVIVO

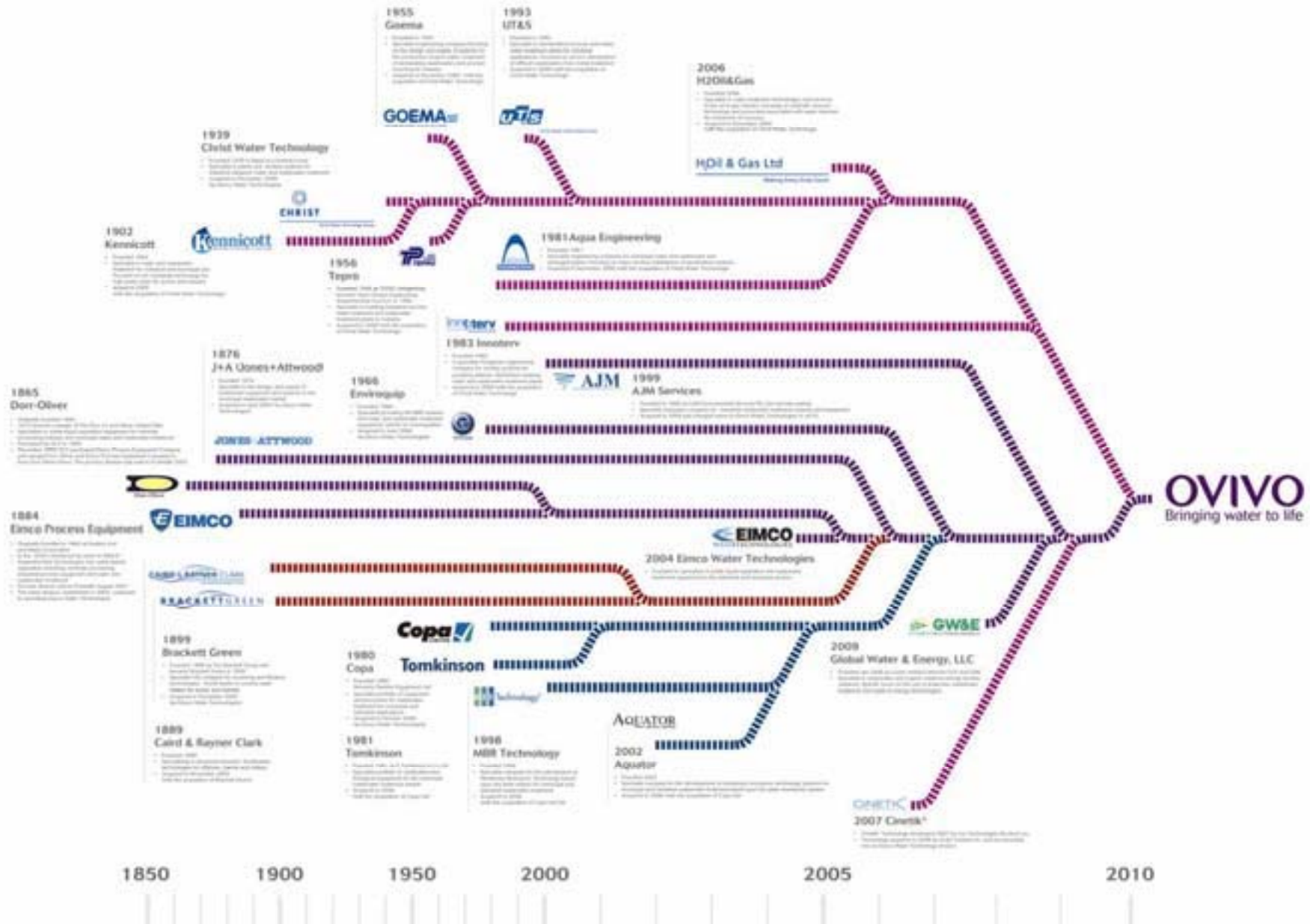

Grain project details.

Grain Site Location

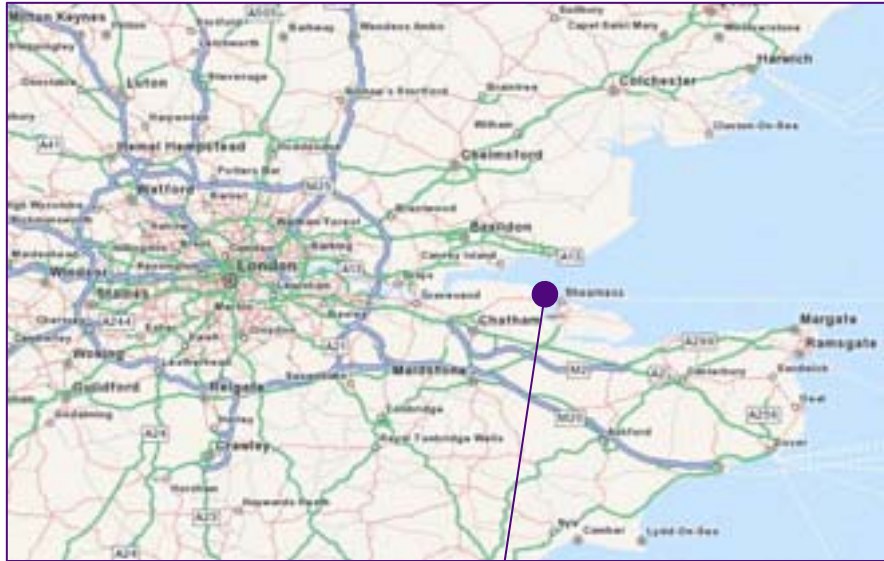

Grain power station is located in north Kent on the northern bank of the river Medway Estuary near the village of Grain.

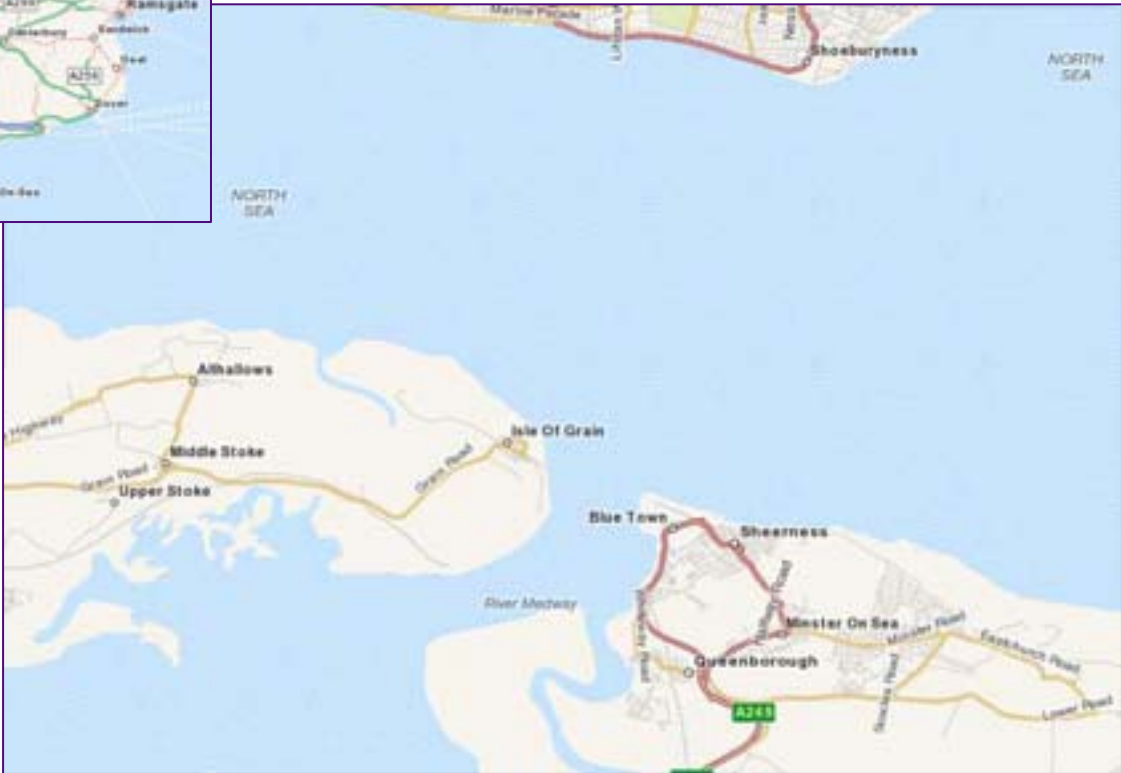

Grain Project Details

1. 1,275MW gas-fired combined heat and power (CHP) station three combined-cycle units that burn natural gas.
2. One of the worlds largest CHP stations overall efficiency expected 72%.
3. Produces enough electricity to supply around a million homes and will also supply 340MW of heat energy to the National Grid LNG terminal. Reduction in carbon emissions of up to 350,000t a year.
4. The first firing of the plant (Unit 6) took place on 2 June 2010.
5. Built by Alstom for E.ON.
6. Use of sea water as potable water resources stressed in area.

Grain Feed Water

Cations	Design range	Anions	Design range
Sodium (Na)	8200-9700 mg/l	Chloride (Cl)	15600-19000 mg/l
Potassium (K)	315-370 mg/l	Sulphate (SO ₄)	2338-2970 mg/l
Calcium (Ca)	330-390 mg/l	Nitrite (NO ₂)	0.005-0.18 mg/l
Magnesium (Mg)	1055-1200 mg/l	Nitrate (NO ₃)	2.6-294 mg/l
Ammonical Nitrogen	0.0036-0.1 mg/l	Ortho Phosphate (PO ₄)	0.2-0.77 mg/l
Total Iron (Fe)	0.01-16.2 mg/l	Fluoride (F)	0.74-1.4mg/l
Aluminium (Al)	0.1-1.54 mg/l	Alkalinity (HCO ₃)	52-162 mg/l
Barium (Ba)	0.04-0.05 mg/l	Reactive (dissolved) Silica (SiO ₂)	0.55-1.35 mg/l
Manganese (Mn)	0.05 mg/l		
Strontium (Sr)	4.2-10.2 mg/l		

Grain Feed Water

Parameter	Design range
Silica SiO ₂ (total)	3.3-14.5 mg/l
Conductivity @ 25°C	37940-48820 μS/cm
pH @ 25 °C	7.3-8.2
Total organic carbon TOC	0.76-4.08 mg/l as C
Biological Oxygen demand (BOD)	1.85-3 mg/l
Chemical Oxygen demand (COD)	240-1040 mg/l
Temperature	10 to 27 °C
Total suspended solids TSS	10-368 mg/l

Grain Treated Water

Parameter	Feed	Design range
Conductivity @ 25°C	49,000 $\mu\text{S}/\text{cm}$	<0.1 $\mu\text{S}/\text{cm}$
Silica	14.5 mg/l	<0.01 mg/l as SiO_2
Iron	1.4 mg/l	<0.02 mg/l as Fe
Copper		< 0.03 mg/l as Cu
Sodium & Potassium	10,000 mg/l	< 0.01 mg/l
Total organic carbon TOC	4.08	< 0.2 mg/l as C

Grain Flow Diagram

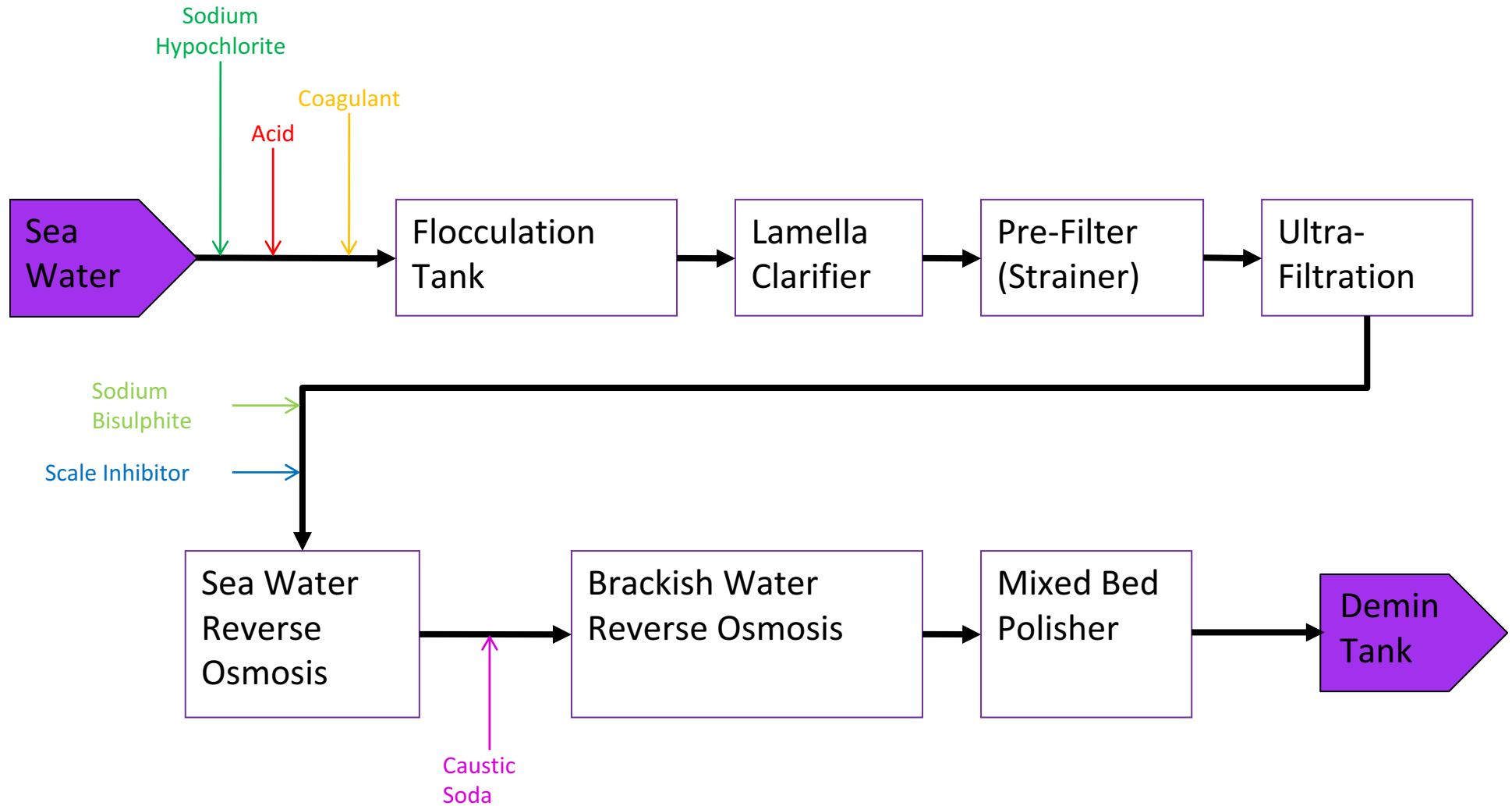

Demineralised Water Flow

Plant output, net of water used for regeneration and backwashing:

- One stream 35m³/h (840 m³/day, 126 l/s)
- Two stream 70m³/h (1680 m³/day, 252 l/s)
 - To achieve maximum flow both trains of UF, SWRO, BWRO and MB operate.
 - Two stream operation reverts to one stream operation if unit not available, for example due to cleaning.
 - Fully Automatic plant.

Installed Equipment

Flocculation and Clarification



Inlet Turbidity
5-150 NTU
368 mg/l Solids

Outlet Turbidity
3 – 4 NTU

Maximum Flow
218 m³/h

Lamella Clarifier Operation

Sea Water + Flocks in

Inlet water flows down & into plate pack at both sides

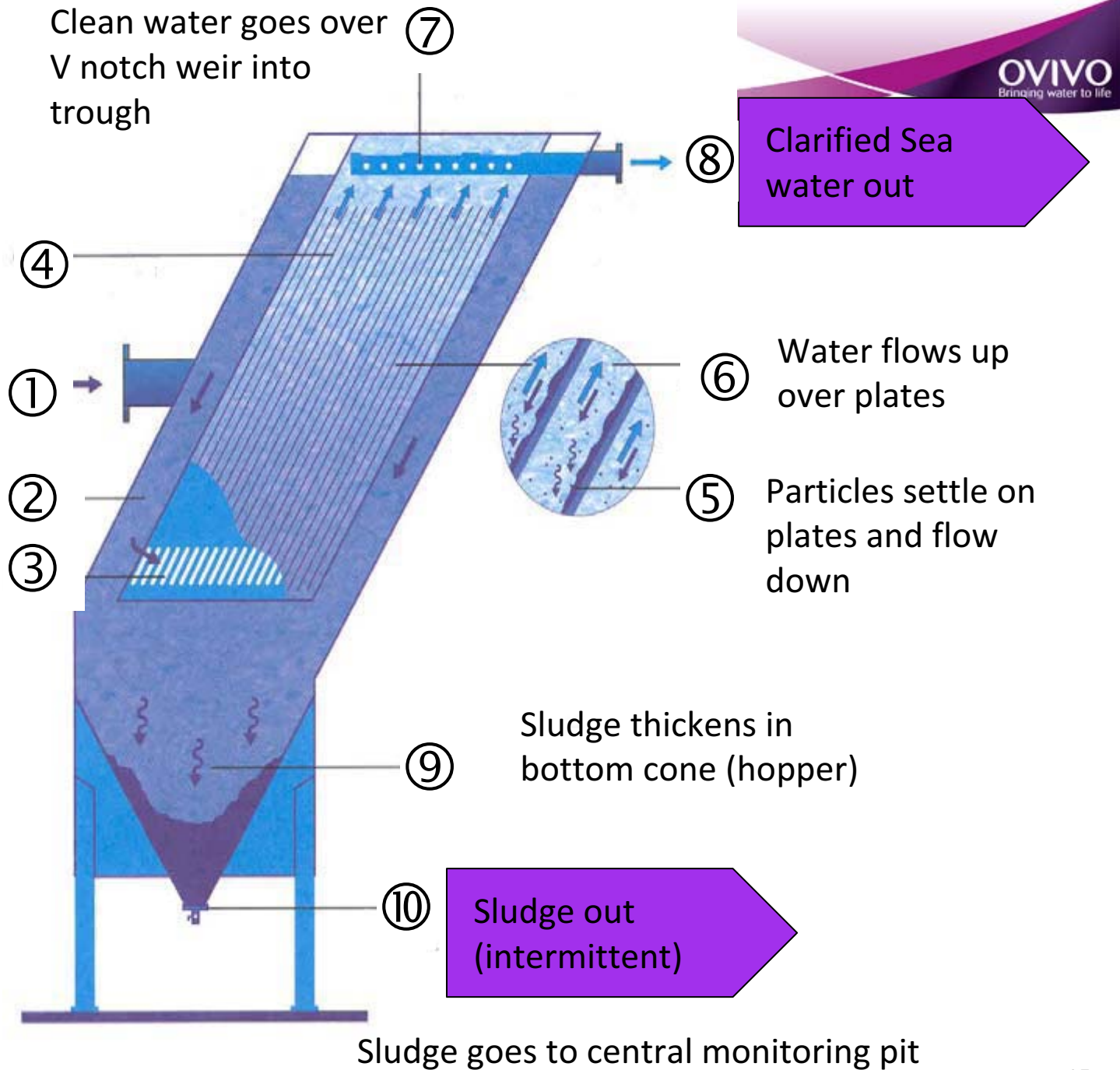

Automatic Filter Cleaning



Filtration

1. Entry
2. Into candle from both ends
3. Through wedge wire
4. Discharge

Back flushing

5. Flow from above into candle
6. Small amount filtrate drawn into candle
7. Waste out

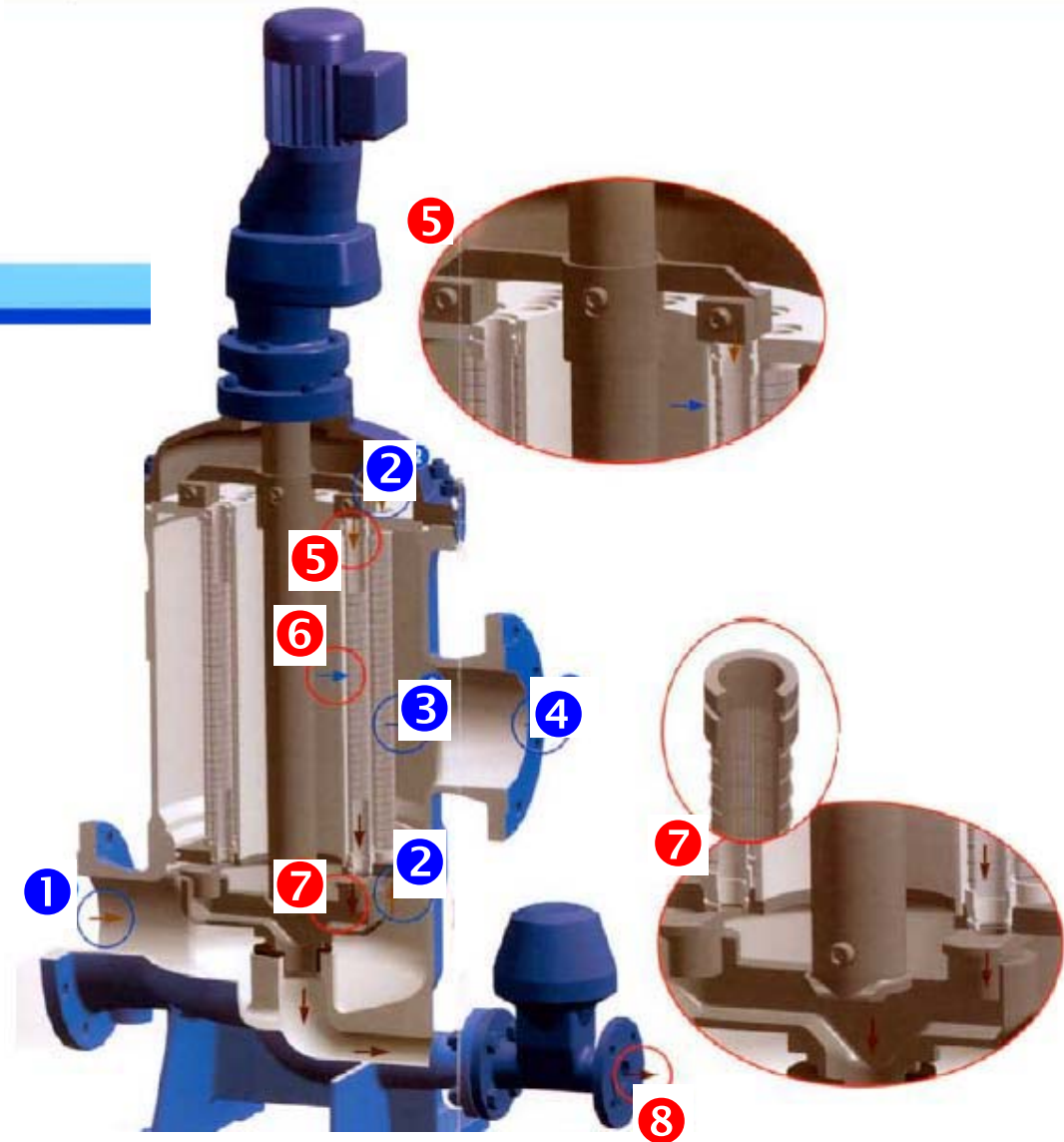

Back Flushing

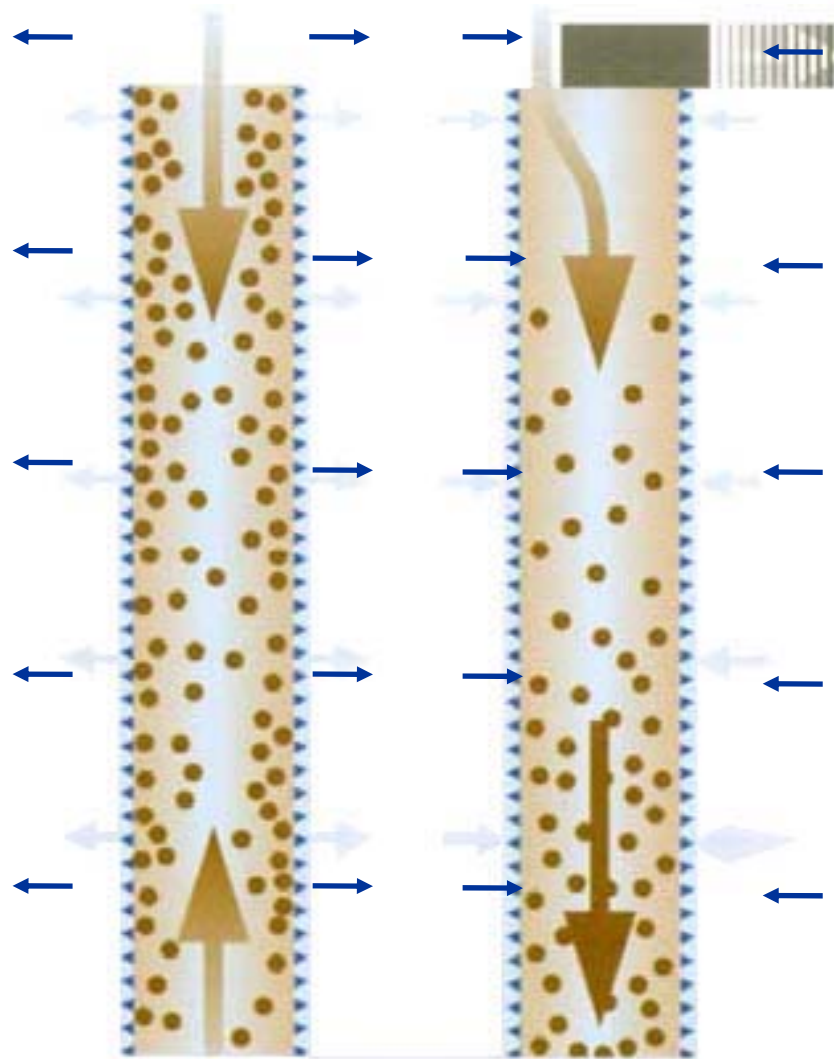

Filtration phase

Backwash phase

Ultrafiltration

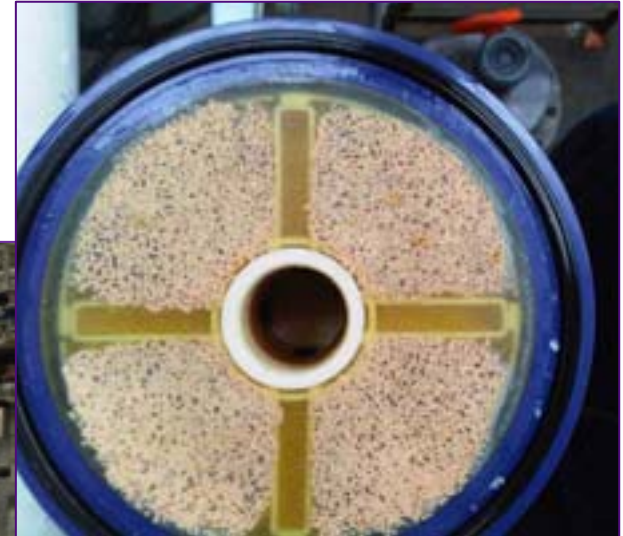
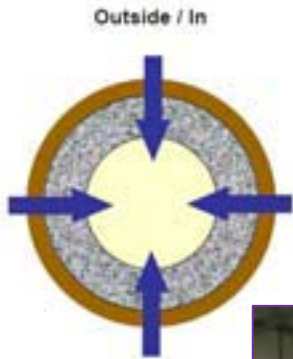

Inlet Turbidity
3 - 4 NTU

Outlet Turbidity
0.1 NTU
SDI < 3

What UF removes

Ultrafiltration removes

- Particles
 - including a portion of colloids like non reactive silica
- High Molecular Weight species
 - including large organics
- Pathogens

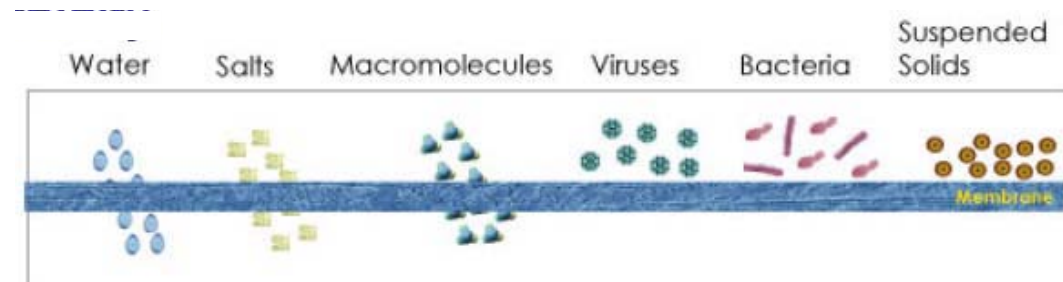

Ultra-filtration does NOT remove

- Dissolved salts
- Most dissolved organics
- Other species like true colour, taste & odour etc...

Backwash Sequence

- 1) Close Valves
- 2) Air Scour
- 3) Drain
- 4) Backwash Stage (i) Top drain
- 5) Backwash Stage (ii) Bottom drain
- 6) Forward Flush

Sea Water Reverse Osmosis



Inlet Conductivity
30,000 – 40,000 $\mu\text{S}/\text{cm}$

Outlet Conductivity
< 300 $\mu\text{S}/\text{cm}$

SWRO 45 % Recovery
Feed 89 m^3/h
Permeate 40 m^3/h
Operating pressure 55 barg



Spiral Wound RO Element

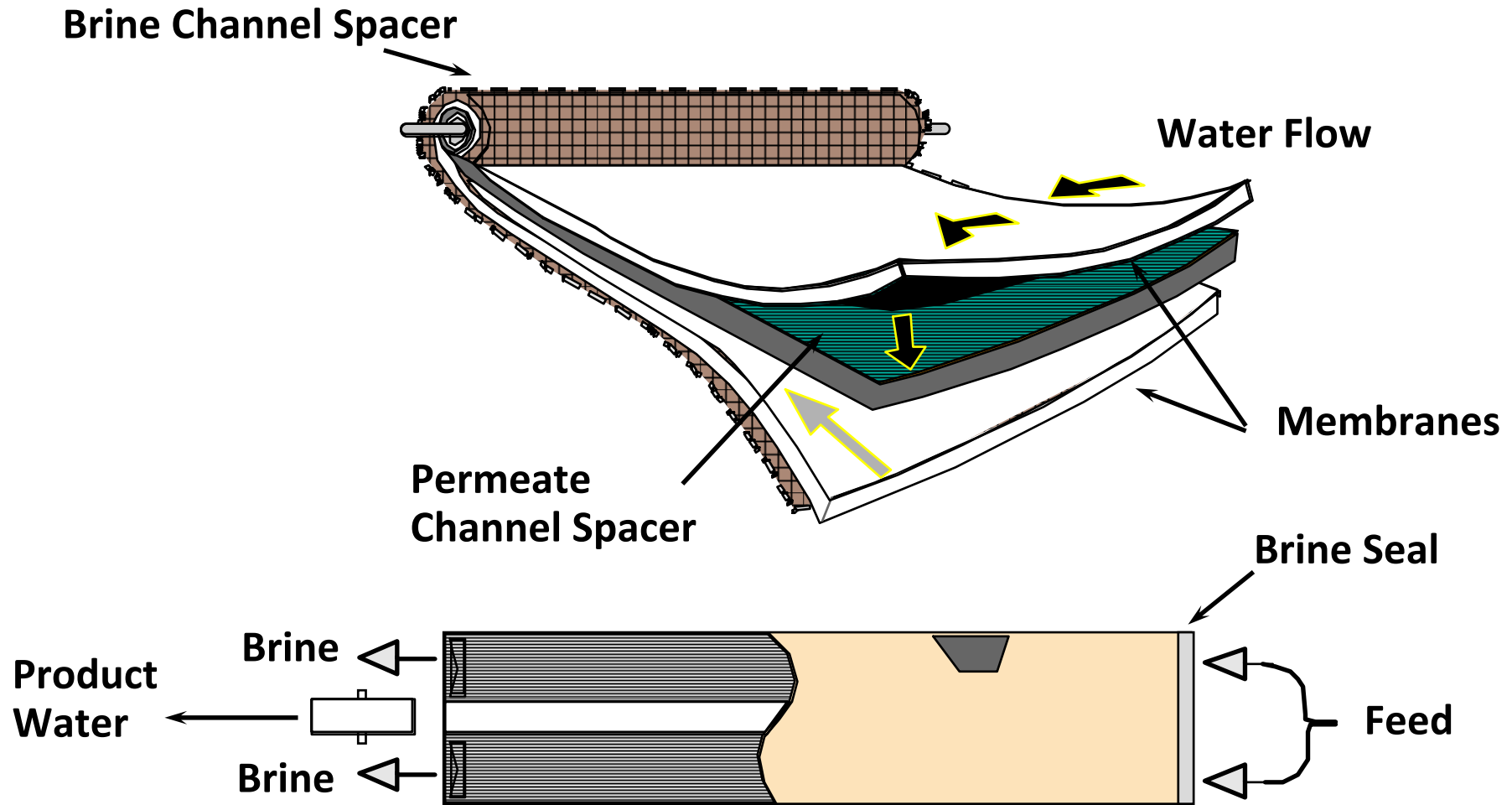

Energy Recovery

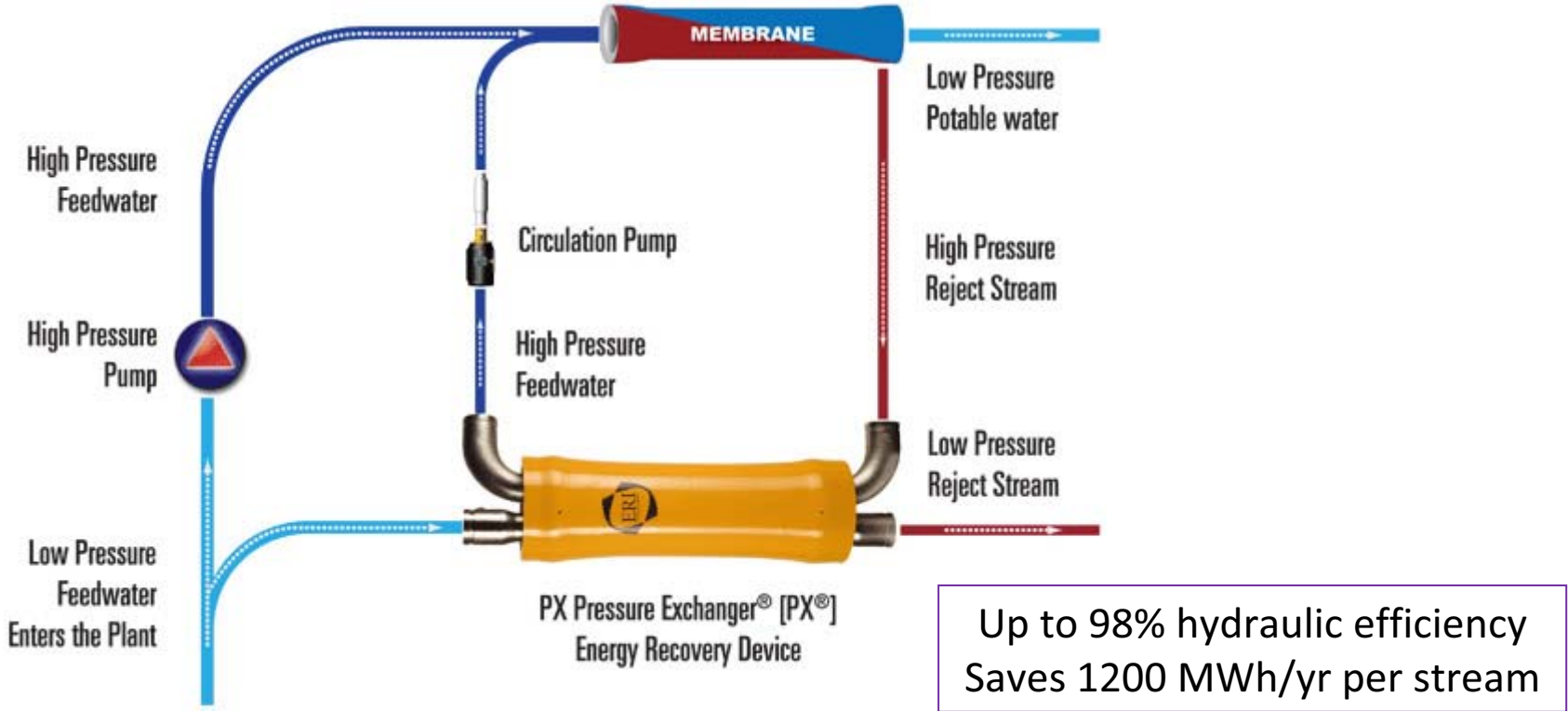

Picture Courtesy of Energy Recovery Inc.

Energy Recovery

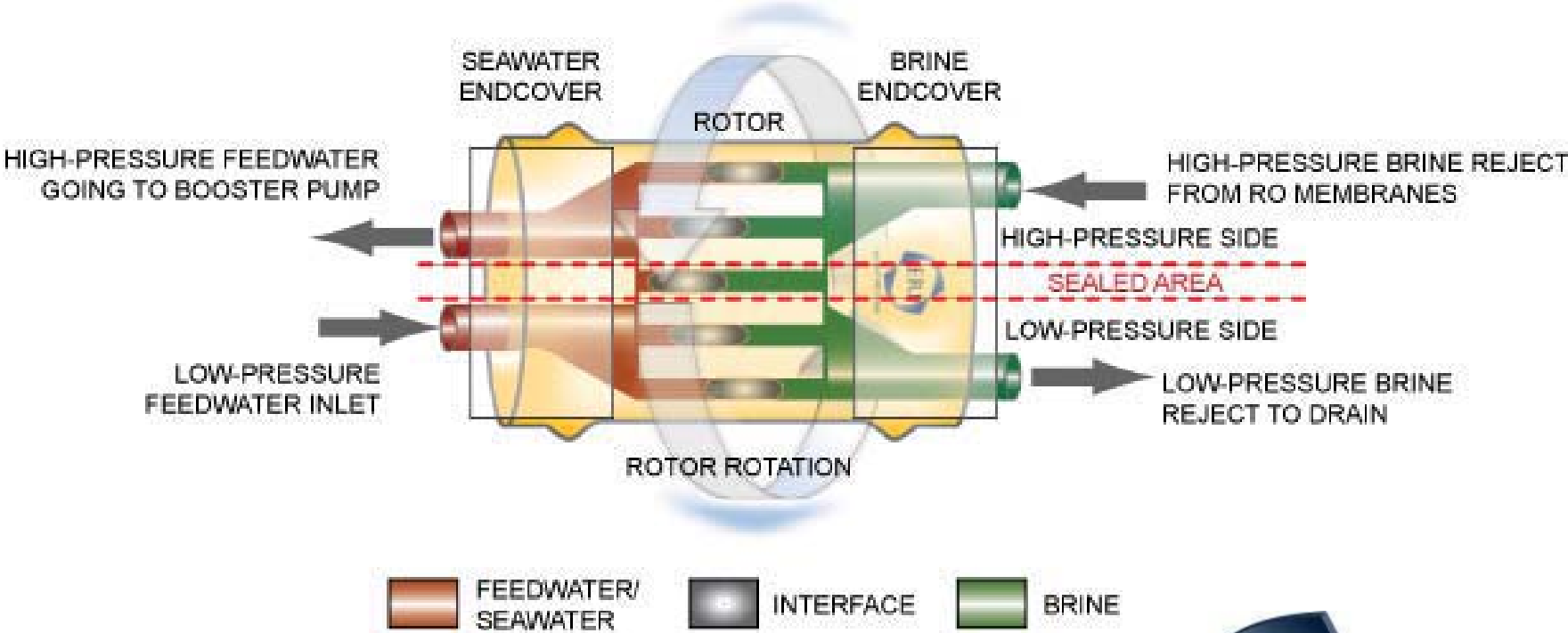

Brackish Water RO Skids

Inlet Conductivity
300 $\mu\text{S}/\text{cm}$

Outlet Conductivity
10 – 15 $\mu\text{S}/\text{cm}$

Recovery 90%
Feed 40 m^3/h
15 barg
Permeate 36 m^3/h



CIP Skid



UF and
RO Cleaning

Dilute
Citric Acid
Oxalic Acid
Caustic

90 m³/h

Mixed Bed Polishing Units

Inlet
Conductivity
10 - 15 $\mu\text{S}/\text{Cm}$

Outlet
Conductivity
< 0.06 $\mu\text{S}/\text{cm}$



Mixed Bed Principle of Operation

Down Flow Service

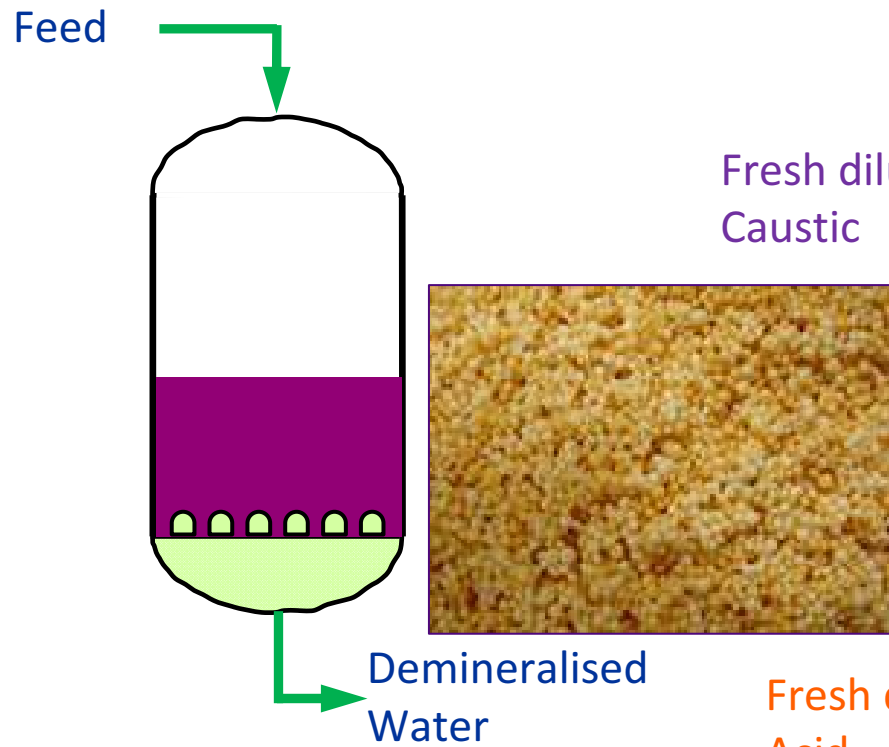

Regeneration

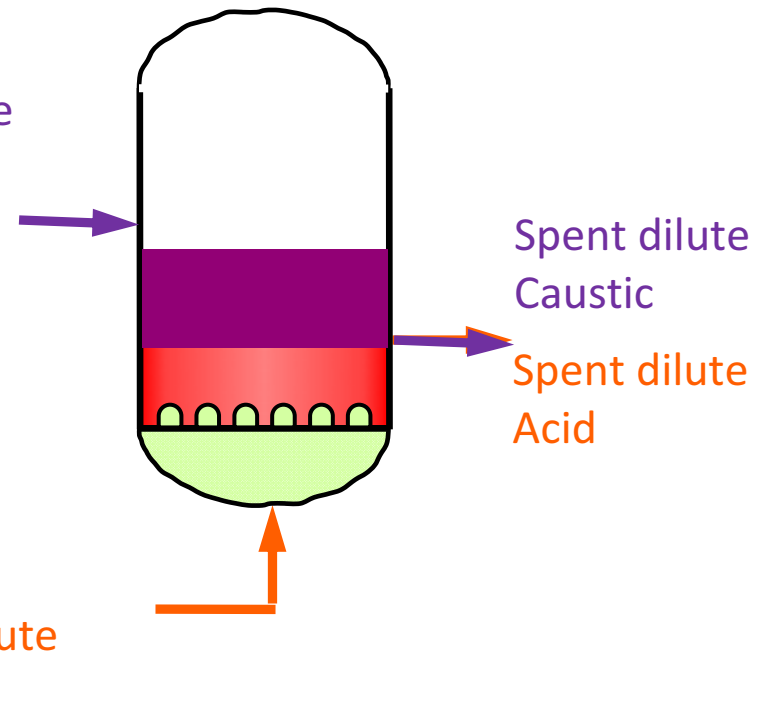

Regeneration Chemicals

Sulphuric Acid

**Grade : High grade (high purity) strength 98 or 96%
diluted to 5%.**



Caustic Soda

**Grade: Rayon grade (high purity) strength 47%.
Diluted to 4%**



Bulk Chemical Storage

Holds 24 m³
98% Sulphuric Acid
Consumption 70 m³/yr

Holds 24 m³
47% Caustic Soda
Consumption 75 m³/yr



3D Plant Model

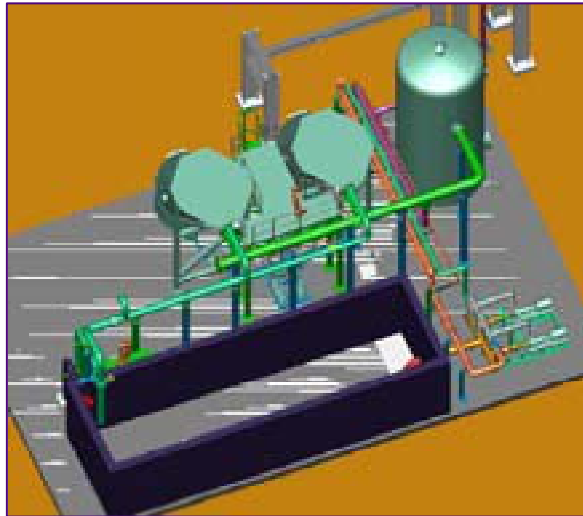

Pre treatment Plant

Main Plant Building

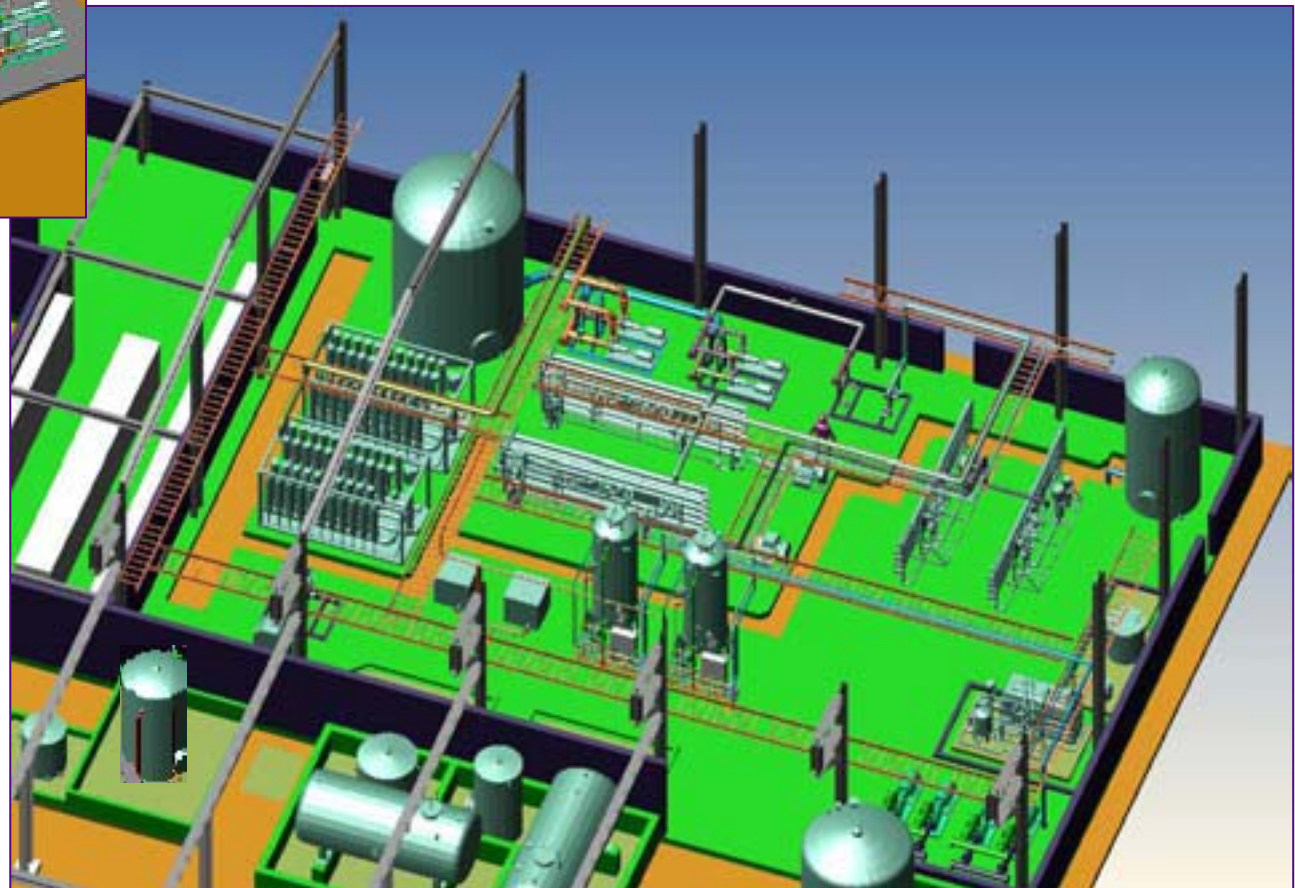

Contact

Chris.Bell@ovivowater.com

+44 (0) 1902 721212